

THE BOOK OF

JOEL



Joel 1:5-6

THE BOOK OF

Wake up, you drunkards, and weep; wail, all you wine drinkers, because of the sweet wine, for it has been taken from your mouth. ⁶For a nation has invaded my land, powerful and without number; its teeth are the teeth of a lion, and it has the fangs of a lioness.

Joel 1:7

It has devastated my grapevine and splintered my fig tree. It has stripped off its bark and thrown it away; its branches have turned white.

THE BOOK OF



Joel 1:8-9

THE BOOK OF

Grieve like a young woman dressed in sackcloth, mourning for the husband of her youth. ⁹Grain and drink offerings have been cut off from the house of the LORD; the priests, who are ministers of the LORD, mourn.



Joel 1:10

**The fields are destroyed; the land grieves;
indeed, the grain is destroyed; the new
wine is dried up; and the fresh oil fails.**

THE BOOK OF



Joel 1:11

**Be ashamed, you farmers, wail, you
vinedressers, over the wheat and the
barley, because the harvest of the field has
perished.**

THE BOOK OF



Joel 1:12

The grapevine is dried up, and the fig tree is withered; the pomegranate, the date palm, and the apple—all the trees of the orchard—have withered. Indeed, human joy has dried up.

THE BOOK OF

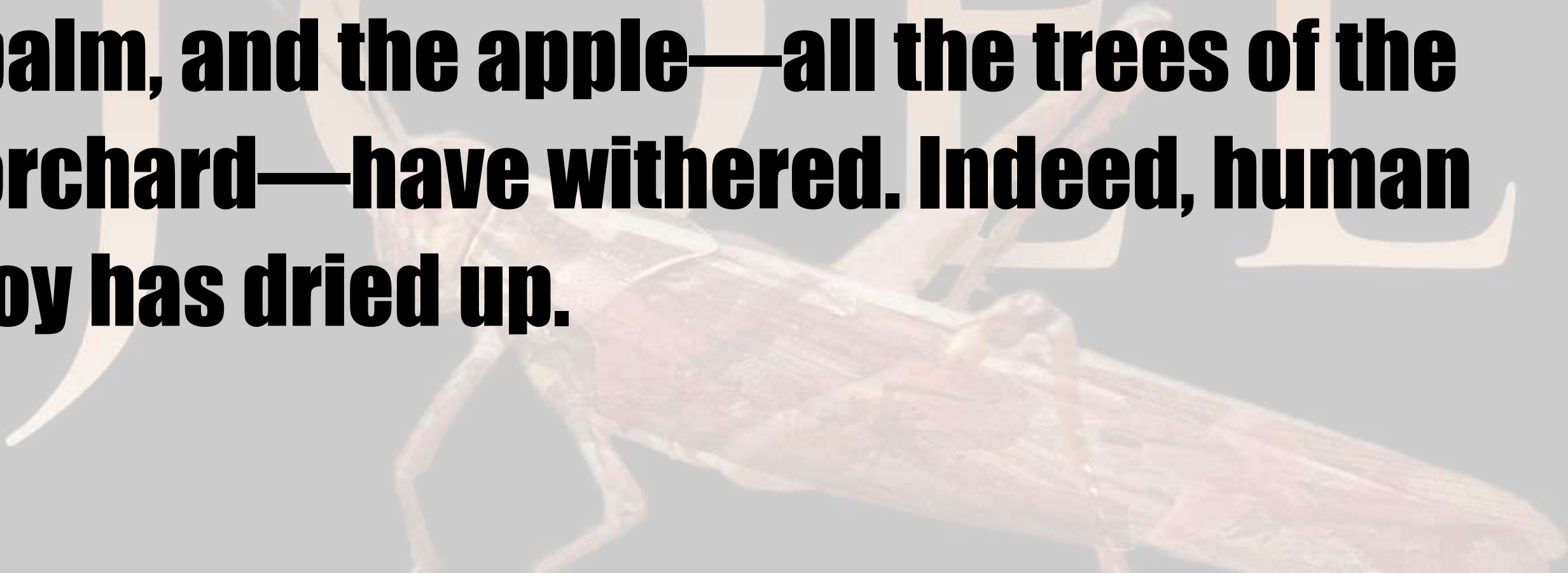

THE BOOK OF

JOEL



THE BOOK OF

HUMANITY'S CONDITION

The Torpidity of Judah

Part 1



THE BOOK OF

JOEL



HIBERNATION

TORPIDITY

AESTIVATION



HIBERNATION

TORPIDITY

AESTIVATION

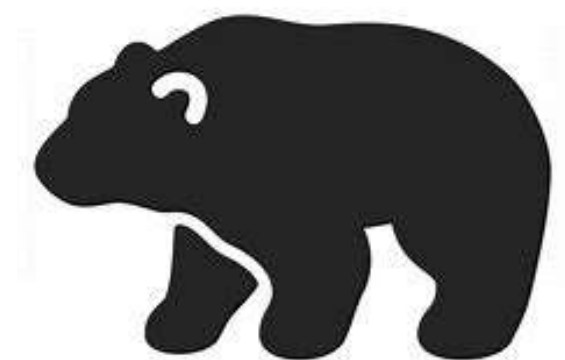

HIBERNATION

TORPIDITY

AESTIVATION

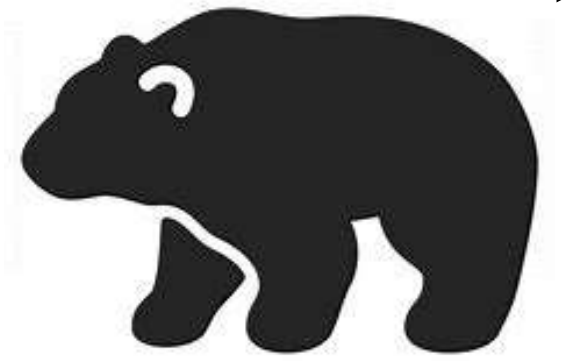

THE BOOK OF

JOEL



GOD NEEDS TO AWAKEN JUDAH

SO THAT THEY'LL UNDERSTAND THE TRAGEDY

SO THAT THEY'LL LAMENT OVER THEIR SIN

SO THAT THEY'LL RETURN TO THE LORD

SO THAT THEY'LL BE BLESSED BY THE LORD

SO THAT THE WORLD WILL BE BLESSED

THE BOOK OF

JOEL



THE BOOK OF

JOEL

Hebrew poetry is undergirded by truth and meant to evoke feelings through the use of imagery.



THE BOOK OF

JOEL



Conveys Truth

Uses Imagery

Meant To Evoke Feelings

Uses Parallelism & Repetition

Pericopes

Chiastic Structures

THE BOOK OF

Q
E
L



CHIASTIC STRUCTURES

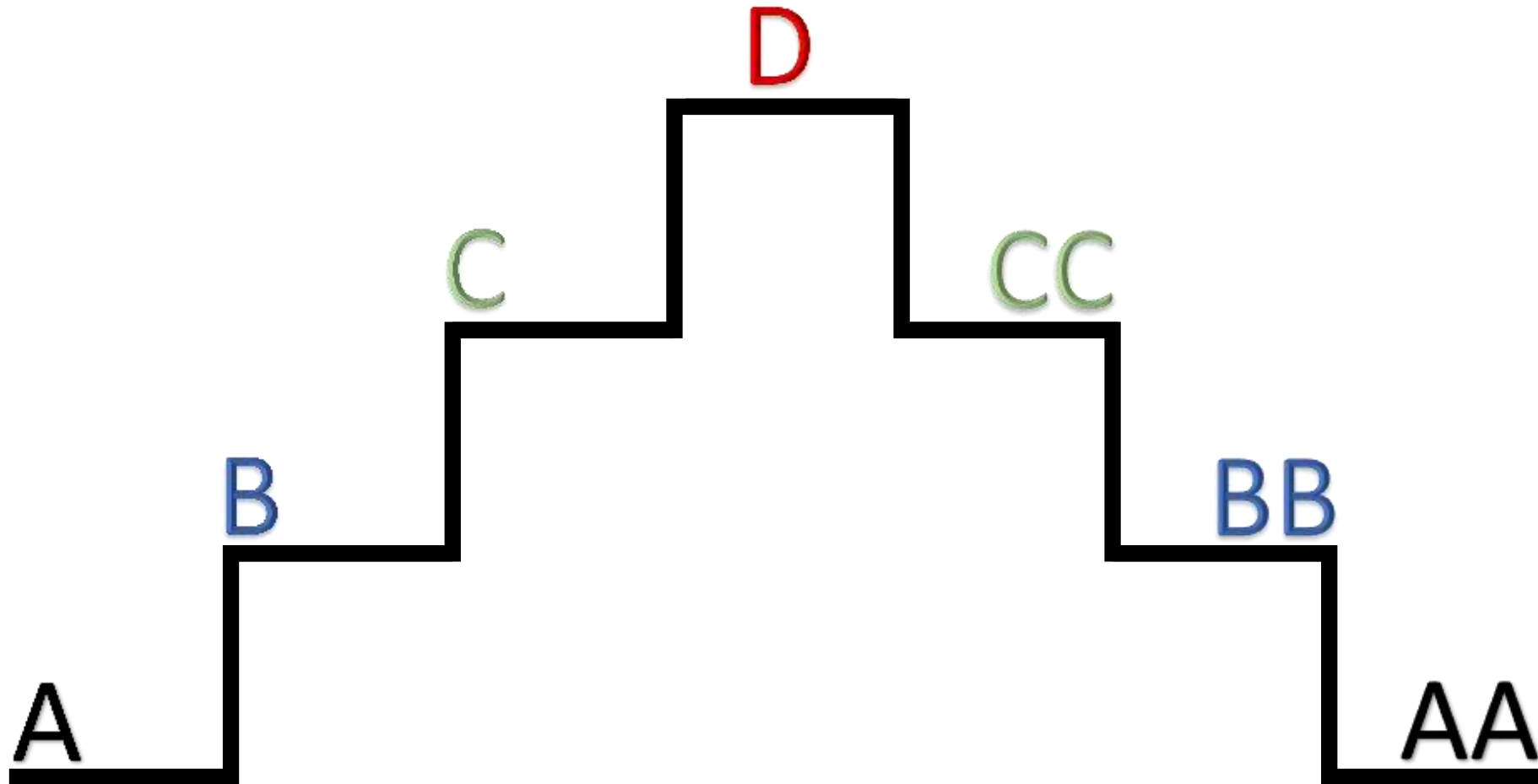

Conveys Truth

Uses Imagery

Meant To Evoke Feelings

Uses Parallelism & Repetition

Pericopes

Chiastic Structures

Word Plays/Sound Plays

Contrasting

Thought Development

Literal Followed By Metaphor (v.v.)

THE BOOK OF

PSALMS



THE BOOK OF

JOEL



MICRO-PERICCOPE #1

JOEL 1:5-7

**WAKE UP FROM YOUR
SPIRITUAL TORPIDITY**

THE BOOK OF

JOEL



Karath – to cut, cut off

Joel 1:5, Genesis 9:11 & 15:18



Karath – to cut, cut off

Joel 1:5, Genesis 9:11 & 15:18

Bathar – to cut in half

Genesis 15:10



Karath – to cut, cut off

Joel 1:5, Genesis 9:11 & 15:18

Bathar – to cut in half

Genesis 15:10

Mul – to be cut off, circumcise

Genesis 17:10-11

THE BOOK OF

JOEL









© 2011
Eam Bui You

THE BOOK OF

JOEL

